

**ANS LEGATO**  
PEDISPA

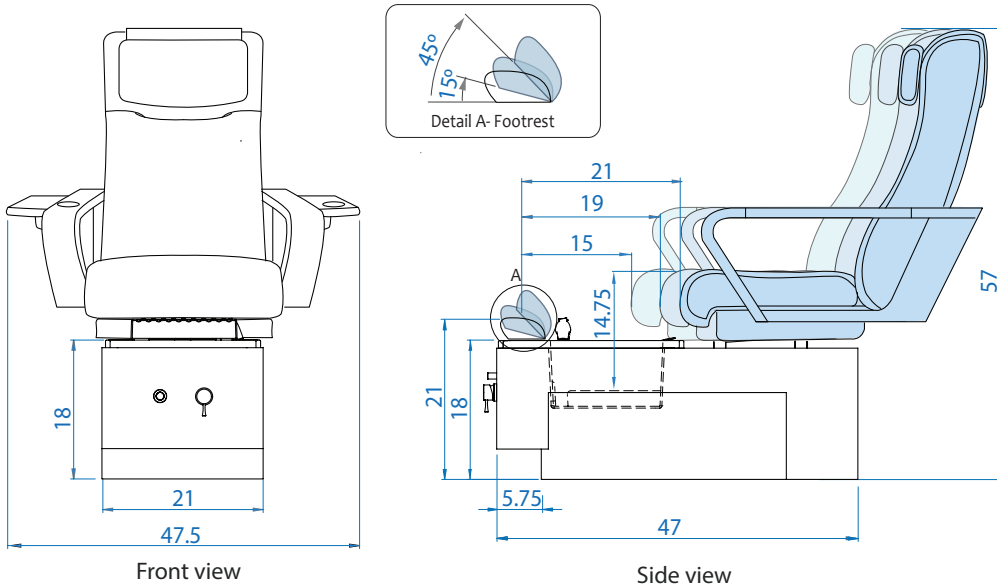

Package weight: 162 lbs.  
Tub w/ floor installation: 150 lbs.  
Sink Bowl Capacity: 4.5 U.S. gallon (17.03L)

Weight capacity: 300lbs



## PARTS IDENTIFICATION

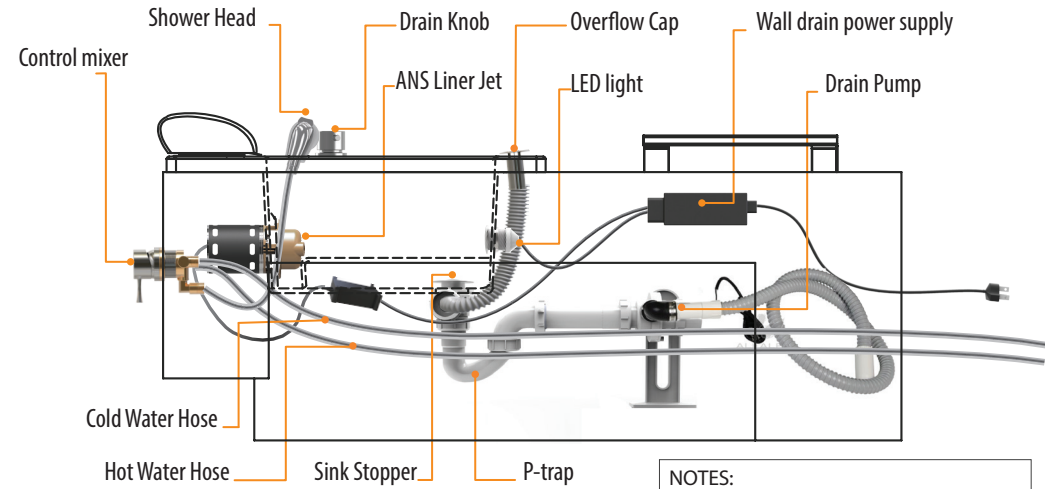

**NOTES:**  
POWER SOURCE: 110V AC/15 AMP 60 HZ (GFI PROTECTED)  
CONFORMS TO  
UL STD 1795 AND UL STD 73  
CERTIFIED TO CSA C 22.2 NO. 218.1  
AND CAN/CSA C 22.2 NO. 68

**UL LISTED**  
E4217221

\* Note: The wall drain system is shown in the above diagram

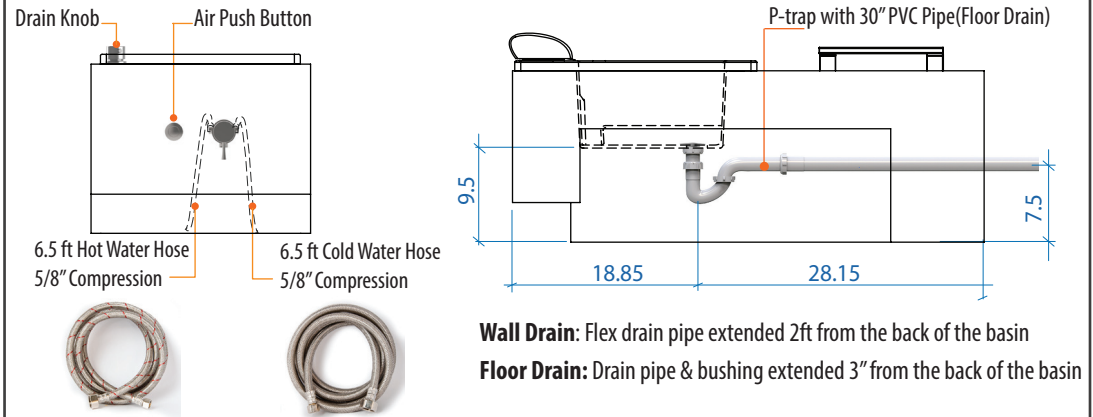

### Wall Drain

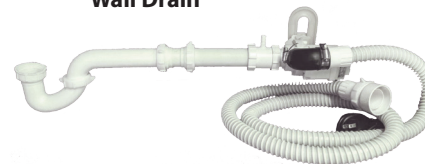

1-5/16" discharge hose after pump with 1-1/2" bushing  
Drain pump - 120V AC, 85W, 60Hz, 1 Amp

### Floor Drain



Drain Pipe - 1-1/2" PVC extendable ~5" above floor